

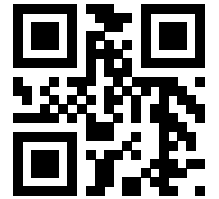

Parts List

90006301_3.0



Flygt SR 4220.011/.090

Table of Contents

1	Introduction.....	2
1.1	Specially approved products.....	2
2	Product Description.....	3
2.1	The data plate.....	3
2.2	Approvals.....	3
2.3	Product denomination.....	4
3	Exploded View.....	6
3.1	Drive unit.....	6
3.2	Hydraulic unit.....	7
3.3	Installation components.....	8
4	List of Parts.....	9
4.1	4220.011/.090.....	9

1 Introduction

Purpose of this manual

The purpose of this manual is to provide necessary information on spare parts and accessories order.

Disclaimer

Always use genuine Flygt parts. The use of other spare parts or accessories can invalidate any claims for warranty or compensation. Xylem does not take any responsibility for damages that are caused by the use of non-original parts. For more information, contact your local sales and service representative.

Data for ordering spare parts

The following information is needed for spare part orders:

- Serial number of the product
- Part number
- Quantity of bulk material, see * in tables

1.1 Specially approved products

Qualification of personnel

Only Xylem or Xylem-authorized service personnel may undertake repair work on specially approved products.

Dimensional accuracy inspection

Spare parts marked with (Ex) after the part number are subject to dimensional accuracy inspection when used in specially approved products.

2 Product Description

2.1 The data plate

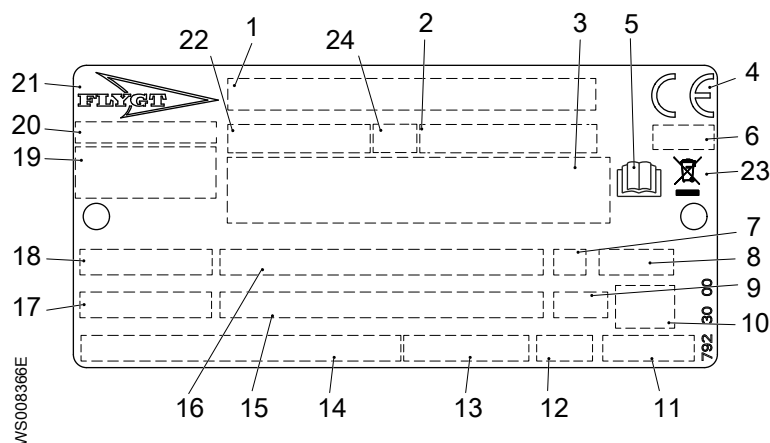

1. Serial number, see [Product denomination](#) on page 4
2. Product number
3. Additional information
4. CE-marking
5. Read installation manual
6. Notified body (only for EN-approved Ex products)
7. Duty class
8. Degree of protection
9. Thermal class
10. Maximum submergence
11. Product weight
12. Direction of rotation: L=left, R=right
13. Speed
14. Minimum rated voltage/rated current – maximum rated voltage/rated current
15. Maximum ambient temperature (2), rated shaft power (2)
16. Maximum ambient temperature (1), rated shaft power (1)
17. Power factor
18. Phase, type of current, frequency
19. Manufacturer
20. Country of origin
21. Brand
22. Sales denomination
23. WEEE-Directive symbol
24. Hydraulic end, type of installation

2.2 Approvals

Product approvals for hazardous locations

Product	Approval
4220.090	European Norm (EN) <ul style="list-style-type: none"> • ATEX Directive • EN IEC 60079-0:2018, EN 60079-1:2014, EN ISO 80079-36:2016, EN ISO 80079-37:2016 •  II 2 G Ex db h IIB T4 Gb
	IEC <ul style="list-style-type: none"> • IECEx scheme • IEC 60079-0:2017, IEC 60079-1:2014-06, ISO 80079-36:2016, ISO 80079-37:2016 • Ex db h IIB T4 Gb
	FM (FM Approvals) <ul style="list-style-type: none"> • Explosion proof for use in Class I, Div. 1, Group C and D

Product	Approval
	CSA Ex • Explosion proof for use in Class I, Div. 1, Group C and D

EN approval plate

This illustration describes the EN approval plate and the information that is contained in its fields.

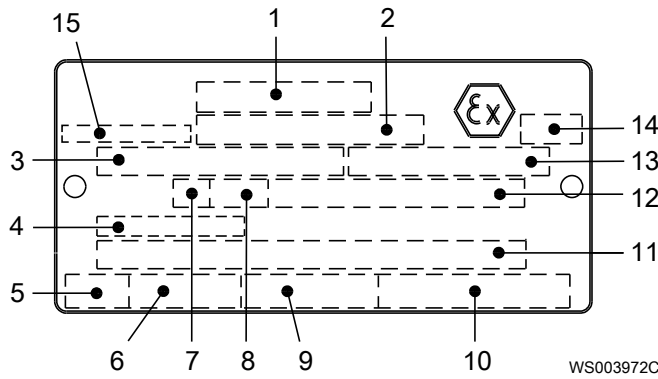

1. Approval
2. Approval authority and Approval number
3. Approved drive unit
4. Cable entry temperature
5. Stall time
6. Starting current or Rated current
7. Duty class
8. Duty factor
9. Input power
10. Rated speed
11. Additional information
12. Maximum ambient temperature
13. Serial number
14. ATEX marking
15. Country of origin

IEC approval plate

This illustration describes the IEC approval plate and the information that is contained in its fields.

International Norm; not for EU member countries.

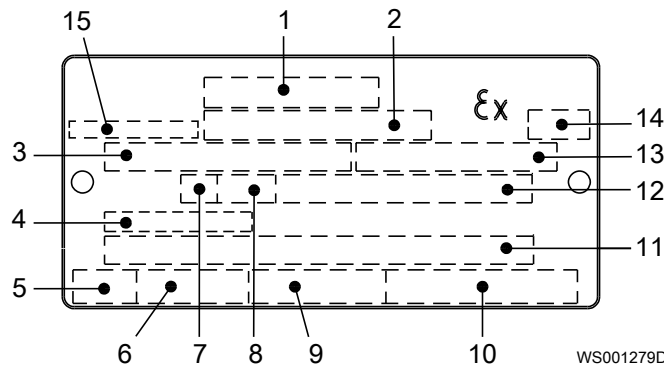

1. Approval
2. Approval authority and Approval number
3. Approved drive unit
4. Cable entry temperature
5. Stall time
6. Starting current or Rated current
7. Duty class
8. Duty factor
9. Input power
10. Rated speed
11. Additional information
12. Maximum ambient temperature
13. Serial number
14. ATEX marking
15. Country of origin

2.3 Product denomination

Reading instruction

In this section, code characters are illustrated accordingly:

X = letter

Y = digit

The different types of codes are marked up with a, b and c. Code parameters are marked up with numbers.

Codes and parameters

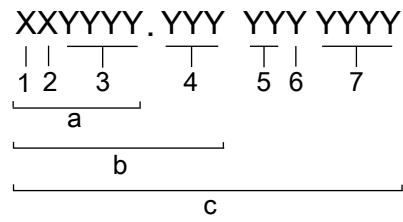

WS006265B

Type of Callout	Number	Indication
Type of code	a	Sales denomination
	b	Product code
	c	Serial number
Parameter	1	Hydraulic end
	2	Type of installation
	3	Sales code
	4	Version
	5	Production year
	6	Production cycle
	7	Running number

3 Exploded View

3.1 Drive unit

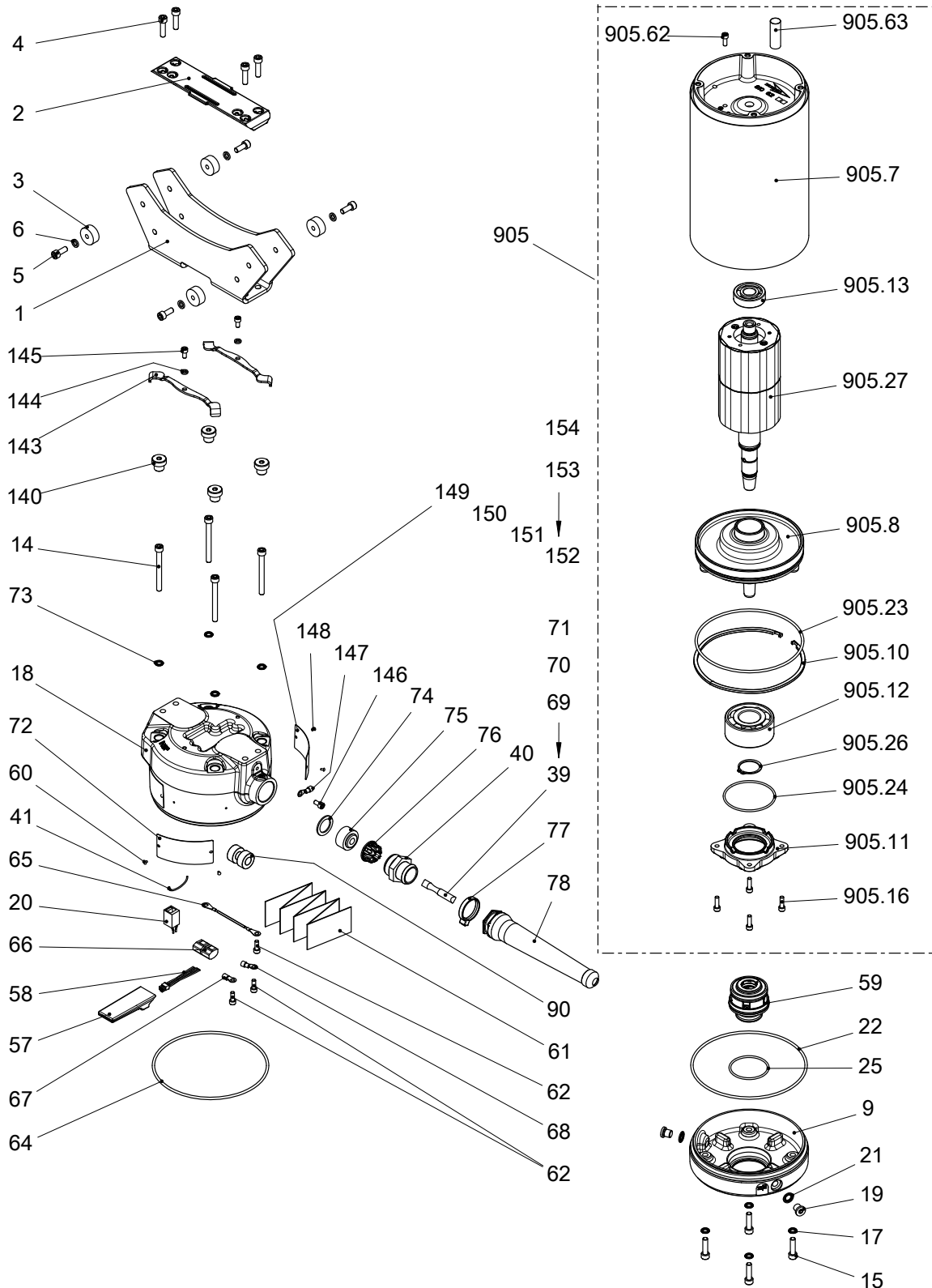

409665B

3.2 Hydraulic unit

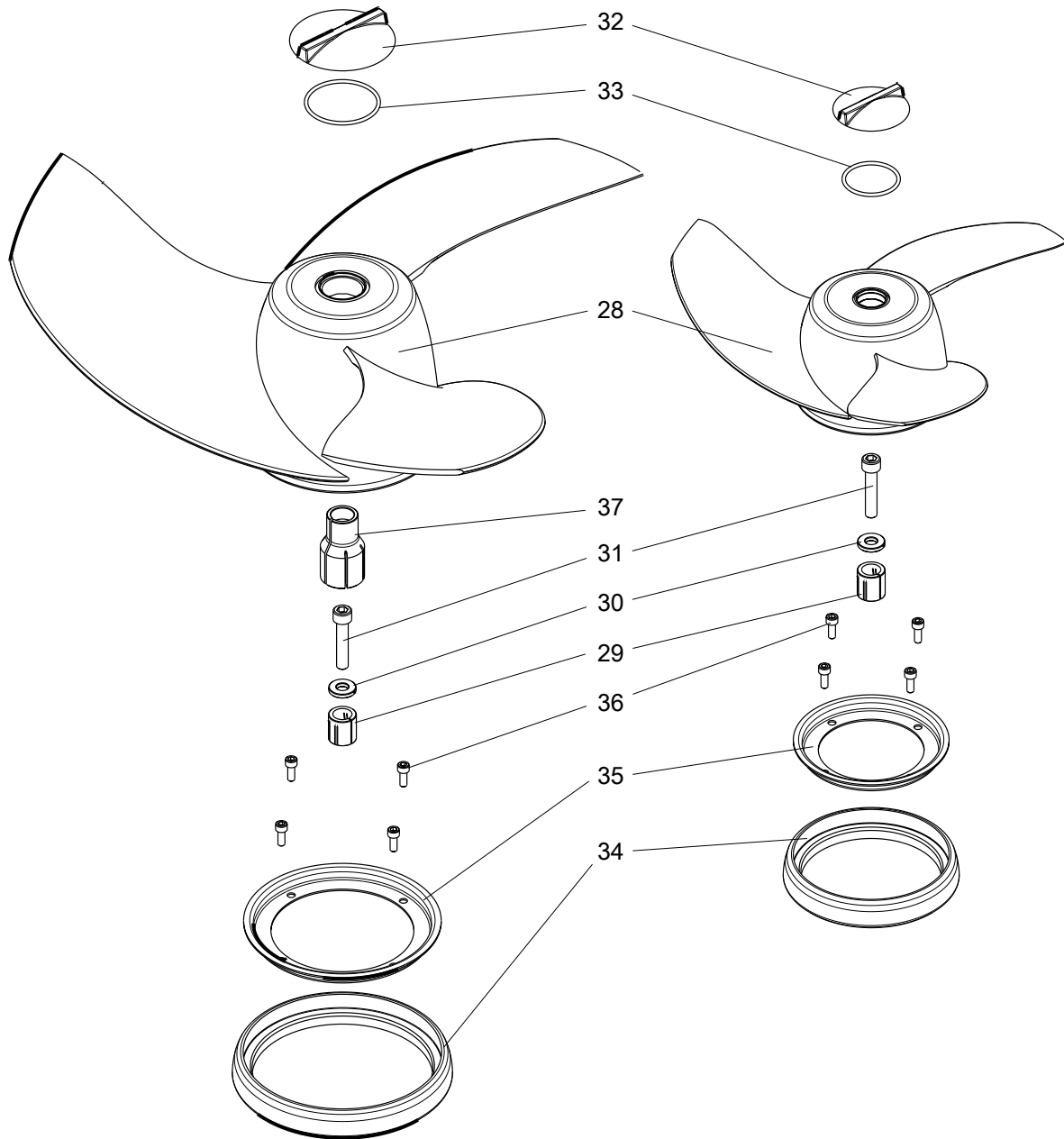

40956A

3.3 Installation components

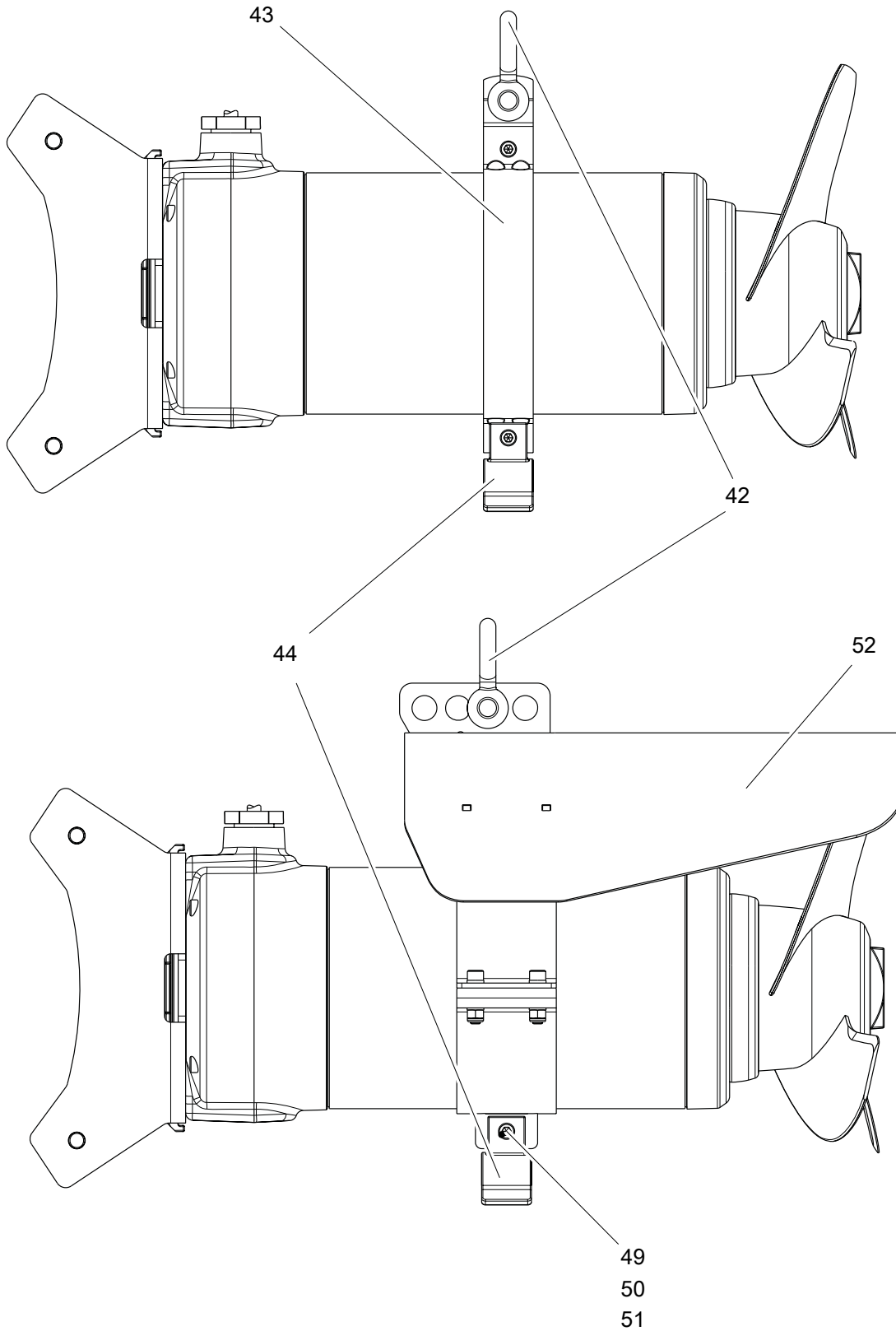

Figure 1: Lifting device and vortex protection shield

40961A

4 List of Parts

4.1 4220.011/.090

Pos. No	Part. No	Type	Denomination	Qty/Version		
				011	090	
1	810 50 00		Sliding bracket	Guide bar: 50 x 50 mm	1	1
1	810 56 00		Sliding bracket	Guide bar: 60 x 60 mm	1	1
1	810 58 00		Sliding bracket	Guide bar: 80 x 80 mm	1	1
1	810 67 00		Sliding bracket	Guide bar: 50 x 100 mm	1	1
1	810 51 00		Sliding bracket	Guide bar: 100 x 100 mm	1	1
2	810 52 00		Plate	Guide bar: 50 x 50 mm Guide bar: 50 x 100 mm	1	
2	810 57 00		Plate	Guide bar: 60 x 60 mm	1	1
2	810 59 00		Plate	Guide bar: 80 x 80 mm	1	1
2	810 53 00		Plate	Guide bar: 100 x 100 mm	1	1
2	810 52 01	(Ex)	Plate	Guide bar: 50 x 50 mm Guide bar: 50 x 100 mm		1
3	630 82 00		Sleeve		4	4
4	83 03 02		Hex.socket hd screw M8X30-A4-70		4	4
5	83 04 48		Hex.socket hd screw M8X20-A4-80		4	4
6	82 50 15		Lock washer NORD-LOCK M8-2340		4	4
9	810 64 00	(Ex)	Seal housing cover u		1	1
14	85 03 45		Hex.socket hd screw ISO 4762 M 8 X110-A4-80		4	
14	85 07 37		Hex.socket hd screw ISO 4762 M8X80-A4-80			4
15	83 03 02		Hex.socket hd screw M8X30-A4-70		4	4
17	583 32 00	(Ex)	Seal washer		4	4
18	810 70 32		Connect. hous.unit		1	
18	810 70 34		Connect. hous.unit		1	
18	810 70 36		Connect. hous.unit		1	
18	810 70 44		Connect. hous.unit		1	
18	810 70 46		Connect. hous.unit		1	
18	810 70 42		Connect. hous.unit		1	
18	810 70 11	(Ex)	Connect. hous.unit			1
18	810 70 13	(Ex)	Connect. hous.unit			1
18	810 70 15	(Ex)	Connect. hous.unit			1
19	85 05 78		Plug		2	2
20	518 89 03	(Ex)	Leakage sensor		1	1
21	85 05 49		Seal washer		2	2
22	85 03 17		O-ring 165.0 X 4.0 FPM		1	1
25	82 71 71		O-ring 62X3.0 FPM		1	1

Pos. No	Part. No	Type	Denomination	Qty/Version	
				011	090
28	810 40 00		Propeller compl. OD: 370 mm	1	
28	810 28 00		Propeller OD: 580 mm	1	1
29	782 72 02		Clamping sleeve	1	1
30	338 13 11		Plain washer 10.5X23.5X4	1	1
31	83 02 00		Hex.socket hd screw M10X50-A4-80	1	1
32	569 15 00		Protective plug Propeller OD: 370 mm	1	
32	569 70 00		Protective plug VINYLESTER Propeller OD: 580 mm DMC+GF	1	1
33	82 80 97		O-ring 44.2X3 FPM Propeller OD: 370 mm	1	
33	82 80 90		O-ring 59.5X3 FPM Propeller OD: 580 mm	1	1
34	810 45 00		Protective ring Propeller OD: 370 mm	1	
34	810 34 00		Protective ring Propeller OD: 580 mm	1	1
35	810 46 00		Holder Propeller OD: 370 mm	1	
35	810 35 00		Holder Propeller OD: 580 mm	1	1
36	83 02 75		Hex.socket hd screw M6X16-A4-70	4	4
37	810 33 00		Sleeve	1	1
38	592 04 00		Caution plate	1	1
39	94 19 90		Motor cable subcab S3X2.5+3X2.5/3+S(4X0.5)	*	*
40	838 14 01	(Ex)	Gland screw	1	1
40	791 15 00		Gland screw ISO G1 1/4"	1	1
41	573 58 70		Single-core cable	1	4
42	82 26 49		Shackle	1	1
43	597 73 01	(Ex)	Lifting handle unit	1	1
	43,1 82 27 27		Lock nut M8-A4-70	2	2
	43,2 82 35 74		Plain washer 8.4X16X1.8-A4-170HV	2	2
	43,3 83 04 45		Hex.socket hd screw M8X35-A4-80	2	2
44	810 71 00		Support Guide bar: 50 x 50 mm Guide bar: 100 x 100 mm	1	1
44	833 24 00		Support Guide bar: 60 x 60 mm Guide bar: 80 x 80 mm Guide bar: 100 x 100 mm	1	1
45	597 73 01	(Ex)	Lifting handle unit	1	1
48	85 08 94		End sleeve	4	4
49	82 27 27		Lock nut M8-A4-70	1	1
50	82 35 74		Plain washer 8.4X16X1.8-A4-170HV	1	1
51	83 04 45		Hex.socket hd screw M8X35-A4-80	1	1
52	791 76 01	(Ex)	Vortex unit	1	1
57	820 83 00		I/o unit	1	1
58	824 95 00		Cable unit	1	1

Pos. No	Part. No	Type	Denomination	Qty/Version		
				011	090	
59	769 87 33		Mechanical seal dbl. AL203/ WCCR,WCCR/WCCR FPM	Material inner seal: Cemented carbide (WCCR) - Cemented carbide (WCCR) Material outer seal: Cemented carbide (WCCR) - Cemented carbide (WCCR)	1	1
59	769 87 34		Mechanical seal dbl. AL203/ WCCR,RSiC/RSiC FPM	Material inner seal: Cemented carbide (WCCR) - Cemented carbide (WCCR) Material outer seal: Silicone carbide (RSiC) - Silicone carbide (RSiC)	1	1
60	82 20 88		Drive screw 4X5-A2/A4		2	4
61	791 48 04		Connection plate		1	1
62	83 02 75		Hex.socket hd screw M6X16- A4-70		4	4
64	85 03 17		O-ring 165.0 X 4.0 FPM		1	1
65	573 58 20		Single-core cable		1	1
66	83 42 67		Terminal block 600V/20A UL		1	1
66	83 42 65		Terminal block 600V/20A UL			1
67	83 43 62		Cable lug UL/CSA 0.50-1.65 MM2 M6		1	1
68	85 10 24		Cable lug		1	1
69	93 00 77		Shrink hose ID=6.4 MM		*	*
70	94 03 33		Shrink hose ID=3.2 MM		*	*
71	94 03 34		Shrink hose ID=6.4 MM		*	*
72	792 30 00		Data plate		1	1
73	583 32 00	(Ex)	Seal washer		4	4
74	82 42 42		Plain washer 24.5X35X2-A4-70		1	1
75	84 17 94		Seal sleeve (18)-20 MM NBR		1	1
76	678 58 20	(Ex)	Cable clip 18-(20) MM		1	1
77	85 10 33		Cable tie		1	1
78	838 13 00		Bending protection		1	1
85	83 45 63		Cable holder		1	1
90	83 95 06		Electrical filter		2	2
140	828 38 00	(Ex)	Screw			4
143	828 81 00	(Ex)	Bracket			2
144	85 07 38		Lock washer			2
145	83 02 73		Hex.socket hd screw M6X12- A4-70			2
146	83 02 73		Hex.socket hd screw M6X12- A4-70			1
147	85 10 24		Cable lug			1
148	82 20 88		Drive screw 4X5-A2/A4			2
149	796 04 00	(Ex)	Certificate plate			1
150	796 04 01	(Ex)	Certificate plate			1
151	796 03 10	(Ex)	Certificate plate			1
152	801 03 04	(Ex)	Name plate			1
153	801 04 00		Caution plate			1

Pos. No	Part. No	Type	Denomination	Qty/Version	
				011	090
154	83 45 59		Cable tie 200X2.4 PA 6/6 -55+105		1
400	667 40 00		Sticker	2	2
401	726 37 00		Caution label	2	2
402	820 22 00		Sticker	2	2
800	85 03 41		O-ring kit	1	1
900	810 76 00		Basic repair kit	1	1
900	810 76 01		Basic repair kit	1	1
901	90 17 52		Oil ISO VG 32	*	*
905	810 84 00		Motor unit Maximum power: 1,10 kW / 1,50 HP Maximum current: 2,30 A Maximum power: 1,50 kW / 2 HP Maximum current: 3,20 A Maximum power: 2,20 kW / 3 HP Maximum current: 4,60 A	1	
905,7	810 62 00		Stator housing unit	1	
905,8	810 65 00		Bearing holder	1	
905,10	810 55 00		Retaining ring	1	
905,11	797 44 00		Bearing cover	1	
905,12	83 30 17		Ball bearing 35X80X34.9 MM	1	
905,13	83 33 13		Ball bearing 20X52X15 MM	1	
905,16	82 00 15		Hex.socket hd screw M6X20- A2-70	4	
905,23	85 03 17		O-ring 165.0 X 4.0 FPM	1	
905,24	81 78 99		O-ring 74.61X3.53 NBR	1	
905,26	82 59 03		Retaining ring SGA 35	1	
905,27	852 32 00		Shaft unit	1	
905,63	836 39 00		Insulating hose	1	
905	810 84 04		Motor unit Maximum power: 2,20 kW / 3 HP Maximum current: 4,60 A Maximum power: 1,50 kW / 2 HP Maximum current: 3,20 A	1	
905,7	810 62 04		Stator housing unit	1	
905,8	810 65 00		Bearing holder	1	
905,10	810 55 00		Retaining ring	1	
905,11	797 44 00		Bearing cover	1	
905,12	83 30 17		Ball bearing 35X80X34.9 MM	1	
905,13	83 33 13		Ball bearing 20X52X15 MM	1	
905,16	82 00 15		Hex.socket hd screw M6X20- A2-70	4	
905,23	85 03 17		O-ring 165.0 X 4.0 FPM	1	
905,24	81 78 99		O-ring 74.61X3.53 NBR	1	
905,26	82 59 03		Retaining ring SGA 35	1	
905,27	852 32 01		Shaft unit	1	
905,63	836 39 00		Insulating hose	1	
905	810 84 06		Motor unit Maximum power: 3 kW / 4 HP Maximum current: 6,50 A	1	

Pos. No	Part. No	Type	Denomination	Qty/Version	
				011	090
905,7	810 62 06		Stator housing unit	1	
905,8	810 65 00		Bearing holder	1	
905,10	810 55 00		Retaining ring	1	
905,11	797 44 00		Bearing cover	1	
905,12	83 30 17		Ball bearing 35X80X34.9 MM	1	
905,13	83 33 13		Ball bearing 20X52X15 MM	1	
905,16	82 00 15		Hex.socket hd screw M6X20-A2-70	4	
905,23	85 03 17		O-ring 165.0 X 4.0 FPM	1	
905,24	81 78 99		O-ring 74.61X3.53 NBR	1	
905,26	82 59 03		Retaining ring SGA 35	1	
905,27	852 32 01		Shaft unit	1	
905,63	836 39 00		Insulating hose	1	
905	810 84 05	(Ex)	Motor unit Maximum power: 1,10 kW / 1,50 HP Maximum current: 2,50 A Maximum power: 2,20 kW / 3 HP Maximum current: 4,60 A Maximum power: 1,50 kW / 2 HP Maximum current: 3,20 A		1
905,7	810 62 05		Stator housing unit		1
905,8	826 29 01		Bearing holder		1
905,10	810 55 00		Retaining ring		1
905,11	797 44 00		Bearing cover		1
905,12	83 30 17		Ball bearing 35X80X34.9 MM		1
905,13	83 33 13		Ball bearing 20X52X15 MM		1
905,16	82 00 15		Hex.socket hd screw M6X20-A2-70		4
905,23	85 03 17		O-ring 165.0 X 4.0 FPM		1
905,24	81 78 99		O-ring 74.61X3.53 NBR		1
905,26	82 59 03		Retaining ring SGA 35		1
905,27	852 32 01		Shaft unit		1
905,63	836 39 00		Insulating hose		1

Xylem |'zīləm|

- 1) The tissue in plants that brings water upward from the roots;
- 2) a leading global water technology company.

We're a global team unified in a common purpose: creating advanced technology solutions to the world's water challenges. Developing new technologies that will improve the way water is used, conserved, and re-used in the future is central to our work. Our products and services move, treat, analyze, monitor and return water to the environment, in public utility, industrial, residential and commercial building services settings. Xylem also provides a leading portfolio of smart metering, network technologies and advanced analytics solutions for water, electric and gas utilities. In more than 150 countries, we have strong, long-standing relationships with customers who know us for our powerful combination of leading product brands and applications expertise with a strong focus on developing comprehensive, sustainable solutions.

For more information on how Xylem can help you, go to www.xylem.com



Xylem Water Solutions Global
Services AB 556782-9253
361 80 Emmaboda
Sweden
Tel: +46-471-24 70 00
Fax: +46-471-24 74 01
<http://tpi.xylem.com>
[www.xylemwatersolutions.com/
contacts/](http://www.xylemwatersolutions.com/contacts/)

Visit our Web site for the latest version of this document and more information

The original instruction is in English. All non-English instructions are translations of the original instruction.

© 2019 Xylem Inc